

Položovací a kotvicí prostředek Positioning and anchor device

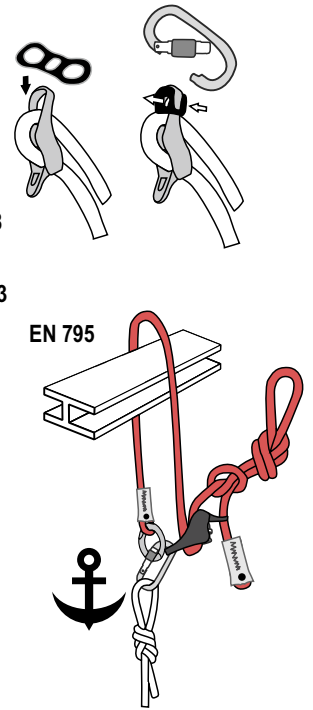

Rock Empire s.r.o.
Ústecká 1918/95, 40502 Děčín
Czech Republic
info@rockempire.com
rockempire.com

N06300

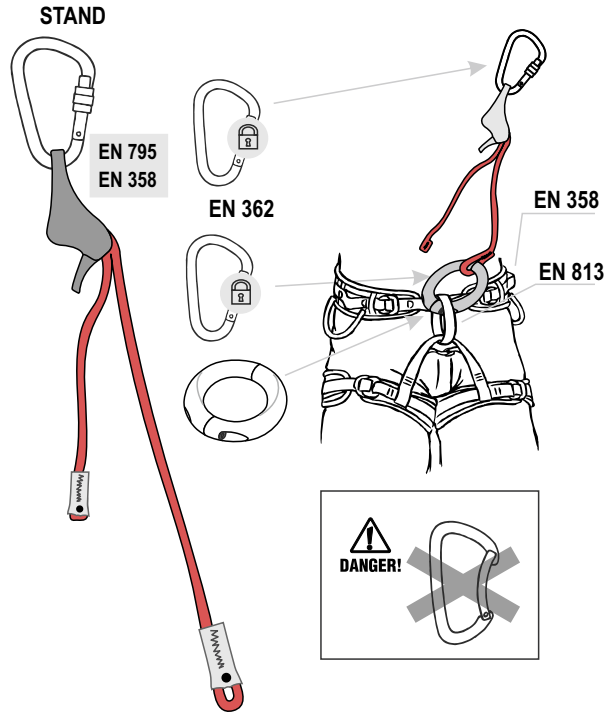

EU type-examination was done and EU conformity to type is performed by Notified Body 1019, VVUÚ a.s., Píkatřská 1337/7, 716 07 Ostrava - Radvanice, Czech Republic

Product conforms to requirements of Regulation (EU) 2016/425.

Prohlášení o shodě uvedeno na:

www.rockempire.com

Declaration of conformity on our website:

max. XXcm	<ul style="list-style-type: none"> Maximum length Maximální délka nastavení
max. XXkg	<ul style="list-style-type: none"> Nominal maximum load Maximální jmenovité zatížení
... xff	<ul style="list-style-type: none"> Maximum users at one time Maximální počet osob ve stejném okamžiku
EN XXX:XX	<ul style="list-style-type: none"> Name of European standard Název evropské normy
CE	<ul style="list-style-type: none"> Indication of conformity with European Directive according to Regulation (EU) 2016/425 Označení shody s evropskou direktivou podle nařízení (EU) 2016/425
1019	<ul style="list-style-type: none"> Identifikacation number of Notified Body carrying out supervision over product quality according to the Regulation (EU) 2016/425; Číslo Oznamného subjektu provádějícího dohled nad jakostí výrobků dle nařízení (EU) 2016/425;
	<ul style="list-style-type: none"> Caution about proper study of manual instruction Upozornění na důkladné prostudování návodu
yyXXxM####	<ul style="list-style-type: none"> Year of manufacture / Product code / Month of manufacture* / running number Rok výroby / kód produktu / měsíc výroby* / individuální číslo

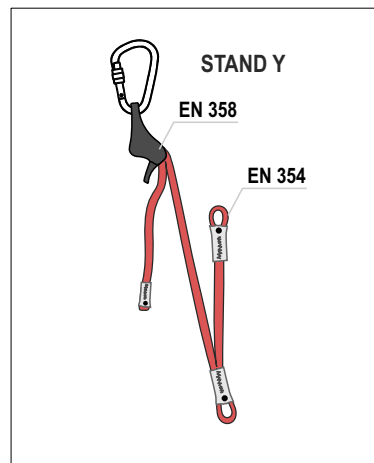
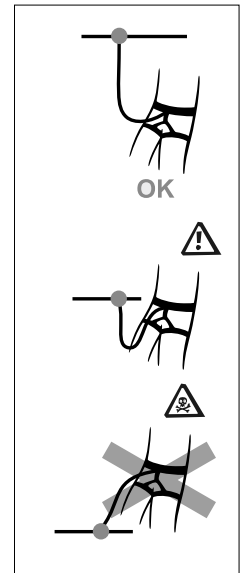
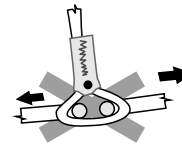
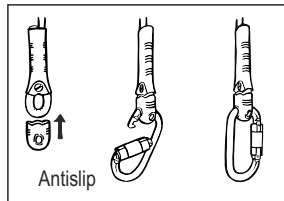

CE 1019

EN 358:18

EN 354:10

Materials:
Stainless Steel, PES,
UHMWPE.

Month of manufacture*

JANUARY	A	M
FEBRUARY	B	N
MARCH	C	O
APRIL	D	P
MAY	E	Q
JUNE	F	R
JULY	G	S
AUGUST	H	T
SEPTEMBER	I	U
OCTOBER	J	V
NOVEMBER	K	Y
DECEMBER	L	Z

